

SG-T

Escalera de aluminio fija entreplantas y altillo. Tramex.

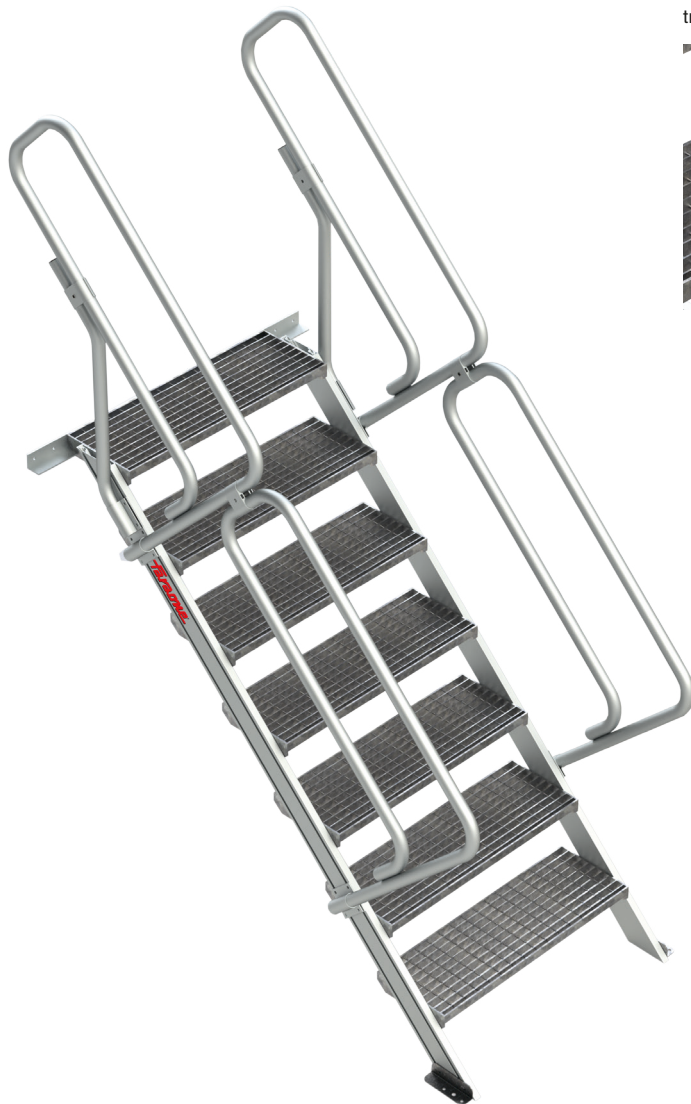

Peldaño antideslizante en tramex de 27 cm.:

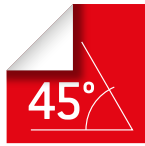
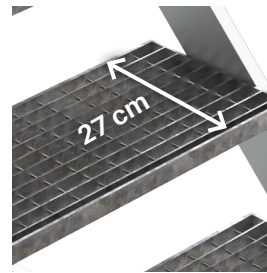

Barandilla de desembarco de 110 cm.:

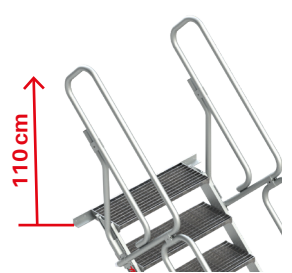

CARACTERÍSTICAS TÉCNICAS

ARTÍCULO	Nº PELDAÑOS	PESO (Kg)	A. (cm)	B. (cm)	C. (cm)	G. (cm)
SG-T-03	3	24	244	64	85	85
SG-T-04	4	33	265	85	85	106
SG-T-05	5	38	286	106	85	128
SG-T-06	6	45	307	127	85	149
SG-T-07	7	50	328	148	85	170
SG-T-08	8	58	350	170	85	191
SG-T-09	9	64	371	191	85	212
SG-T-10	10	71	392	212	85	234
SG-T-11	11	77	413	233	85	255
SG-T-12	12	84	434	254	85	276

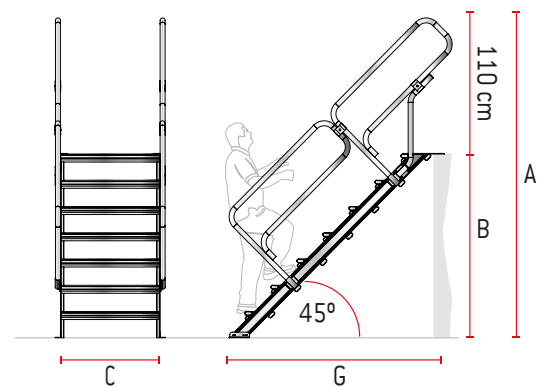

ACCESORIOS OPCIONALES

ARTÍCULO	DESCRIPCIÓN
SGE-PLA-85	Plataforma de trabajo 85x100 cm.
S-CANCF85	Cancela de seguridad frontal 85 cm.
NFC	Nuevo sistema de revisión de producto. Más información info@faraone.es



NFC
Nuevo sistema de revisión del producto.

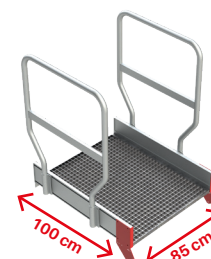

SGE-PLA-85
Plataforma de trabajo de 85x100 cm.



S-CANCF85
Cancela de seguridad frontal de 85 cm.