

# SP-T

Escalera de puente de aluminio con plataforma de Tramex.

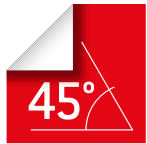

NUEVO SISTEMA DE REVISIÓN:  
Más información [info@taraone.es](mailto:info@taraone.es)



Peldaño antideslizante en tramex de 27 cm.:

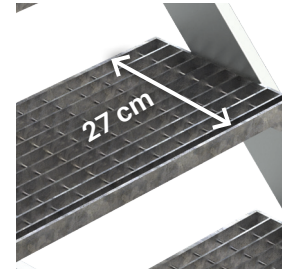

Amplia plataforma de trabajo en tramex de 85x100 cm.:

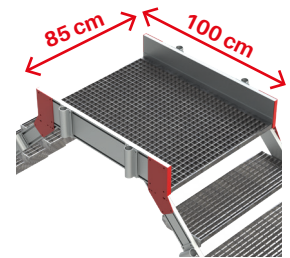

## CARACTERÍSTICAS TÉCNICAS

ARTÍCULO	Nº PELDAÑOS	PESO (Kg)	A. (cm)	B. (cm)	C. (cm)	G. (cm)
SP-T-03	3	60	244	64	85	216
SP-T-04	4	71	265	85	85	258
SP-T-05	5	88	286	106	85	298
SP-T-06	6	100	307	127	85	340
SP-T-07	7	112	328	148	85	383
SP-T-08	8	124	350	170	85	425
SP-T-09	9	140	371	191	85	468
SP-T-10	10	152	392	212	85	510
SP-T-11	11	165	413	233	85	553
SP-T-12	12	181	434	254	85	595

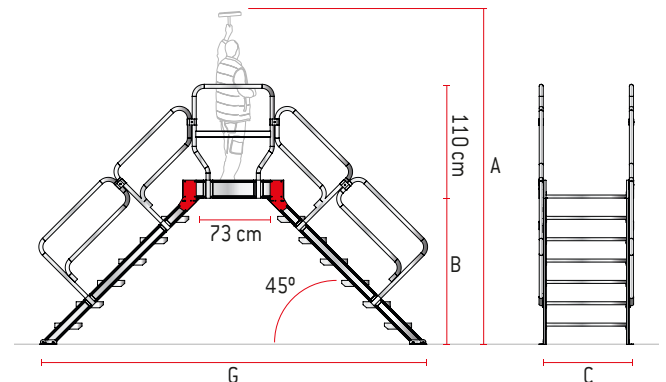

Nota: Se entrega desmontado. Montaje sencillo.

## ACCESORIOS OPCIONALES

### BAS-R125

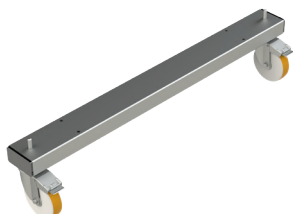

Base con 4 ruedas. \*Con el Opcional cumplirla con la norma 131.7